



Compact™ 1769-OB16 Solid State 24V dc Source Output Module

Installation Instructions

Inside

Module Description	2
Module Installation	3
System Assembly	4
Mounting Expansion I/O.....	5
Replacing a Single Module within a System	7
Field Wiring Connections	7
I/O Memory Mapping	10
Specifications.....	11
Hazardous Location Considerations	15
Environnements dangereux	15
For More Information	16

Module Description

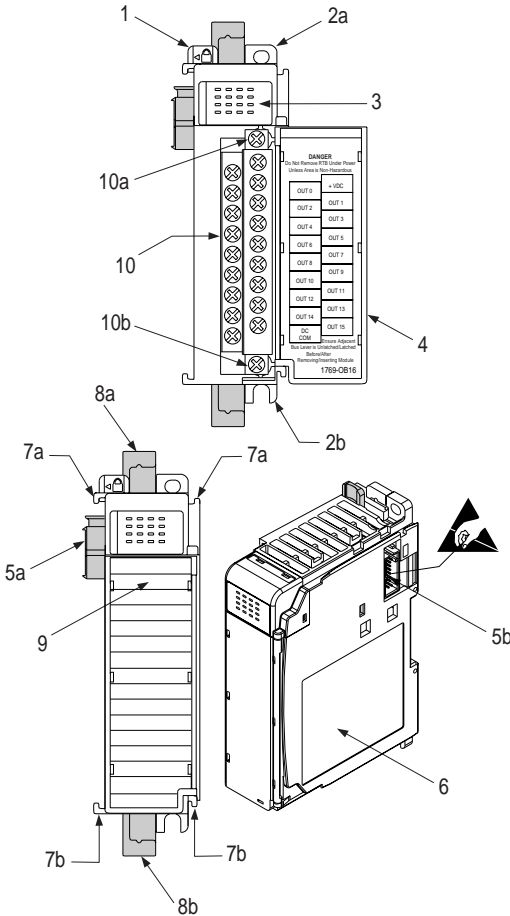

Item	Description
1	bus lever (with locking function)
2a	upper panel mounting tab
2b	lower panel mounting tab
3	I/O diagnostic LEDs
4	module door with terminal identification label
5a	movable bus connector with female pins
5b	stationary bus connector with male pins
6	nameplate label
7a	upper tongue-and-groove slots
7b	lower tongue-and-groove slots
8a	upper DIN rail latch
8b	lower DIN rail latch
9	write-on label (user ID tag)
10	removable terminal block (RTB) with finger-safe cover
10a	RTB upper retaining screw
10b	RTB lower retaining screw

Module Installation

Compact I/O is suitable for use in an industrial environment when installed in accordance with these instructions. Specifically, this equipment is intended for use in clean, dry environments (Pollution degree 2¹) and to circuits not exceeding Over Voltage Category II² (IEC 60664-1).³

Prevent Electrostatic Discharge



ATTENTION: Electrostatic discharge can damage integrated circuits or semiconductors if you touch bus connector pins. Follow these guidelines when you handle the module:

- Touch a grounded object to discharge static potential.
- Wear an approved wrist-strap grounding device.
- Do not touch the bus connector or connector pins.
- Do not touch circuit components inside the module.
- If available, use a static-safe work station.
- When not in use, keep the module in its static-shield box.

Remove Power



ATTENTION: Remove power before removing or inserting this module. When you remove or insert a module with power applied, an electrical arc may occur. An electrical arc can cause personal injury or property damage by:

- sending an erroneous signal to your system's field devices, causing unintended machine motion
- causing an explosion in a hazardous environment

Electrical arcing causes excessive wear to contacts on both the module and its mating connector. Worn contacts may create electrical resistance.

1. Pollution Degree 2 is an environment where, normally, only non-conductive pollution occurs except that occasionally a temporary conductivity caused by condensation shall be expected.
2. Over Voltage Category II is the load level section of the electrical distribution system. At this level transient voltages are controlled and do not exceed the impulse voltage capability of the product's insulation.
3. Pollution Degree 2 and Over Voltage Category II are International Electrotechnical Commission (IEC) designations.

System Assembly

The module can be attached to the controller or an adjacent I/O module *before* or *after* mounting. For mounting instructions, see “Panel Mounting” on page 5, or “DIN Rail Mounting” on page 6. To work with a system that is already mounted, see “Replacing a Single Module within a System” on page 7.

The following procedure shows you how to assemble the Compact I/O system.

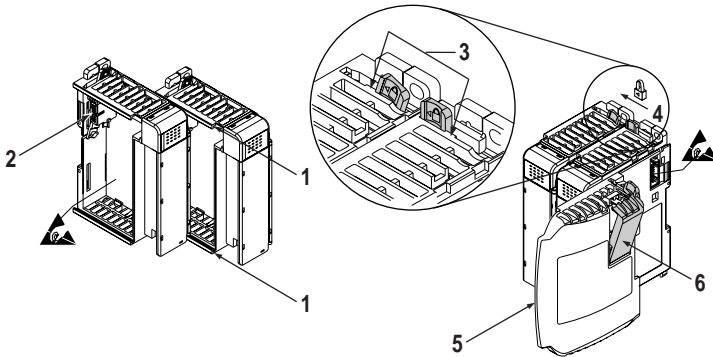

1. Disconnect power.
2. Check that the bus lever of the module to be installed is in the unlocked (fully right) position.
3. Use the upper and lower tongue-and-groove slots (1) to secure the modules together (or to a controller).
4. Move the module back along the tongue-and-groove slots until the bus connectors (2) line up with each other.
5. Push the bus lever back slightly to clear the positioning tab (3). Use your fingers or a small screw driver.
6. To allow communication between the controller and module, move the bus lever fully to the left (4) until it clicks. Ensure it is locked firmly in place.



ATTENTION: When attaching I/O modules, it is very important that the bus connectors are securely locked together to ensure proper electrical connection.

7. Attach an end cap terminator (5) to the last module in the system by using the tongue-and-groove slots as before.
8. Lock the end cap bus terminator (6).

IMPORTANT: A 1769-ECR or 1769-ECL right or left end cap must be used to terminate the end of the serial communication bus.

Mounting Expansion I/O



ATTENTION: During panel or DIN rail mounting of all devices, be sure that all debris (metal chips, wire strands, etc.) is kept from falling into the module. Debris that falls into the module could cause damage on power up.

Minimum Spacing

Maintain spacing from enclosure walls, wireways, adjacent equipment, etc. Allow 50 mm (2 in.) of space on all sides for adequate ventilation, as shown:

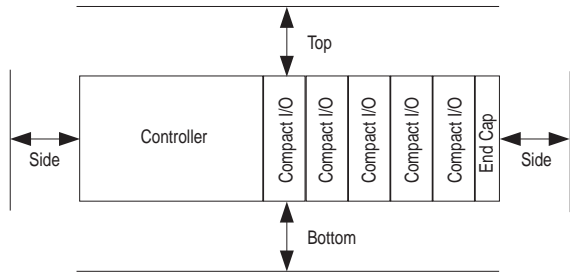

Panel Mounting

Mount the module to a panel using two screws per module. Use M4 or #8 panhead screws. Mounting screws are required on every module.

Panel Mounting Using the Dimensional Template

For more than 2 modules: (number of modules - 1) X 35 mm (1.38 in.)
Refer to host controller documentation for this dimension.

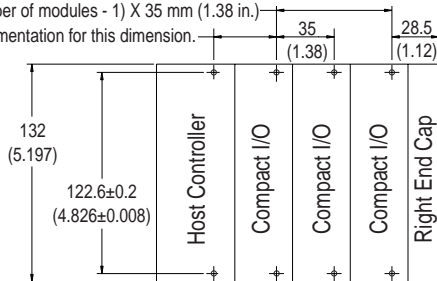

NOTE: All dimensions are in mm (inches). Hole spacing tolerance: ± 0.4 mm (0.016 in.)

Panel Mounting Procedure Using Modules as a Template

The following procedure allows you to use the assembled modules as a template for drilling holes in the panel. If you have sophisticated panel mounting equipment, you can use the dimensional template provided on page 5. Due to module mounting hole tolerance, it is important to follow these procedures:

1. On a clean work surface, assemble no more than three modules.
2. Using the assembled modules as a template, carefully mark the center of all module-mounting holes on the panel.
3. Return the assembled modules to the clean work surface, including any previously mounted modules.
4. Drill and tap the mounting holes for the recommended M4 or #8 screw.
5. Place the modules back on the panel, and check for proper hole alignment.
6. Attach the modules to the panel using the mounting screws.

Note: If mounting more modules, mount only the last one of this group and put the others aside. This reduces remounting time during drilling and tapping of the next group.

7. Repeat steps 1 to 6 for any remaining modules.

DIN Rail Mounting

The module can be mounted using the following DIN rails: 35 x 7.5 mm (EN 50 022 - 35 x 7.5) or 35 x 15 mm (EN 50 022 - 35 x 15).

Before mounting the module on a DIN rail, close the DIN rail latches. Press the DIN rail mounting area of the module against the DIN rail. The latches will momentarily open and lock into place.

Replacing a Single Module within a System

The module can be replaced while the system is mounted to a panel (or DIN rail).

1. Remove power. See important note on page 3.
2. On the module to be removed, remove the upper and lower mounting screws from the module (or open the DIN latches using a flat-blade or phillips style screw driver).
3. Move the bus lever to the right to disconnect (unlock) the bus.
4. On the right-side adjacent module, move its bus lever to the right (unlock) to disconnect it from the module to be removed.
5. Gently slide the disconnected module forward. If you feel excessive resistance, check that the module has been disconnected from the bus, and that both mounting screws have been removed (or DIN latches opened).

Note: It may be necessary to rock the module slightly from front to back to remove it, or, in a panel-mounted system, to loosen the screws of adjacent modules.

6. Before installing the replacement module, be sure that the bus lever on the module to be installed, and on the right-side adjacent module are in the unlocked (fully right) position.
7. Slide the replacement module into the open slot.
8. Connect the modules together by locking (fully left) the bus levers on the replacement module and the right-side adjacent module.
9. Replace the mounting screws (or snap the module onto the DIN rail).

Field Wiring Connections

Grounding the Module

This product is intended to be mounted to a well-grounded mounting surface such as a metal panel. Additional grounding connections from the module's mounting tabs or DIN rail (if used), are not required unless the mounting surface cannot be grounded. Refer to *Industrial Automation Wiring and Grounding Guidelines*, Allen-Bradley publication 1770-4.1, for additional information.

Output Wiring

Basic wiring¹ of output devices² to the 1769-OB16 is shown below.



ATTENTION:

- Miswiring of the module to an AC power source or applying reverse polarity will damage the module.
- Be careful when stripping wires. Wire fragments that fall into a module could cause damage at power up. Once wiring is complete, ensure the module is free of all metal fragments.

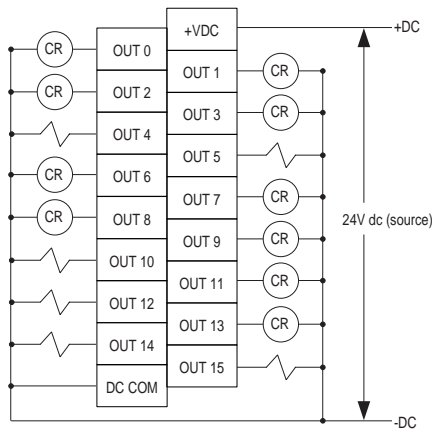

A removable, write-on label is provided with the module. Remove the label from the door, mark the identification of each terminal with permanent ink, and slide the label back into the door. Your markings (ID tag) will be visible when the module door is closed.

1. **Recommended Surge Suppression** - Use a 1N4004 diode reverse-wired across the load for transistor outputs switching 24V dc inductive loads. For additional details, refer to Industrial Automation Wiring and Grounding Guidelines, Allen-Bradley publication 1770-4.1.
2. **Sourcing Output** - Source describes the current flow between the I/O module and the field device. Sourcing output circuits supply (source) current to sinking field devices. Field devices connected to the negative side (DC Common) of the field power supply are sinking field devices. Field devices connected to the positive side (+V) of the field supply are sourcing field devices. *Europe:* DC sinking input and sourcing output module circuits are the commonly used options.

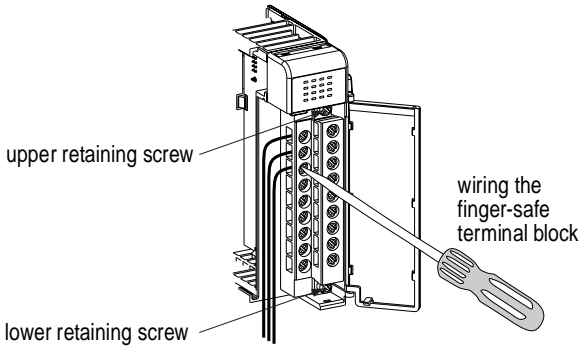

Removing the Finger-Safe Terminal Block

To remove the terminal block, loosen the upper and lower retaining screws. The terminal block will back away from the module as you remove the screws. When replacing the terminal block, torque the retaining screws to 0.46 Nm (4.1 in-lbs).

Wiring the Finger-Safe Terminal Block

When wiring the terminal block, keep the finger-safe cover in place.

1. Loosen the terminal screws to be wired.
2. Route the wire under the terminal pressure plate. You can use the bare wire or a spade lug. The terminals will accept a 6.35 mm (0.25 in.) spade lug.
3. Tighten the terminal screw making sure the pressure plate secures the wire. Recommended torque when tightening terminal screws is 0.68 Nm (6 in-lbs).

Note: If you need to remove the finger-safe cover, insert a screw driver into one of the square, wiring holes and gently pry the cover off. If you wire the terminal block with the finger-safe cover removed, you will not be able to put it back on the terminal block because the wires will be in the way.

Wire Size and Terminal Screw Torque

Each terminal accepts up to two wires with the following restrictions:

Wire Type		Wire Size	Terminal Screw Torque	Retaining Screw Torque
Solid	Cu-90°C (194°F)	#14 to #22 AWG	0.68 Nm (6 in-lbs)	0.46 Nm (4.1 in-lbs)
Stranded	Cu-90°C (194°F)	#16 to #22 AWG	0.68 Nm (6 in-lbs)	0.46 Nm (4.1 in-lbs)

I/O Memory Mapping

Output Data File

For each module, slot x, word 0 in the output data file contains the control program's directed state of the discrete output points.

Word	Bit Position															
	15	14	13	12	11	10	9	8	7	6	5	4	3	2	1	0
0	w	w	w	w	w	w	w	w	w	w	w	w	w	w	w	w

w = write

Output Module's Input Data File

For each module, slot x, input data file word 0 contains the state of the module's output data (output data echo) file word 0. During normal operation, these input bits represent the logic state that the outputs are directed to by the control program. They are also dependent upon the:

- Program Mode configuration (if supported by the controller)
- The Fault Mode configuration (if supported by the controller)

Word	Bit Position															
	15	14	13	12	11	10	9	8	7	6	5	4	3	2	1	0
0	r	r	r	r	r	r	r	r	r	r	r	r	r	r	r	r

r = read

IMPORTANT: The output module's input data file reflects the output data echo of the module, not necessarily the electrical state of the output terminals. It does not reflect shorted or open outputs.

Note: It is only important to use this input word if the controller supports the Program Mode or Fault Mode function, and if it is configured to use them.

Specifications

General Specifications

Specification	Value
Dimensions	118 mm (height) x 87 mm (depth) x 35 mm (width) height including mounting tabs is 138 mm 4.65 in. (height) x 3.43 in (depth) x 1.38 in (width) height including mounting tabs is 5.43 in.
Approximate Shipping Weight (with carton)	280g (0.61 lbs.)
Storage Temperature	-40°C to +85°C (-40°F to +185°F)
Operating Temperature	0°C to +60°C (32°F to +140°F)
Operating Humidity	5% to 95% non-condensing
Operating Altitude	2000 meters (6561 feet)
Vibration	Operating: 10 to 500 Hz, 5g, 0.015 in. peak-to-peak Relay Operation: 2g
Shock	Operating: 30g panel mounted (20g DIN rail mounted) Relay Operation: 7.5g panel mounted (5g DIN rail mounted) Non-Operating: 40g panel mounted (30g DIN rail mounted)
Agency Certification	<ul style="list-style-type: none"> • C-UL certified (under CSA C22.2 No. 142) • UL 508 listed • CE compliant for all applicable directives
Hazardous Environment Class	Class I, Division 2, Hazardous Location, Groups A, B, C, D (UL 1604, C-UL under CSA C22.2 No. 213)
Radiated and Conducted Emissions	EN50081-2 Class A
<i>Electrical /EMC:</i>	<i>The module has passed testing at the following levels:</i>
• ESD Immunity (IEC1000-4-2)	• 4kV contact, 8 kV air, 4 kV indirect
• Radiated Immunity (IEC1000-4-3)	• 10 V/m, 80 to 1000 MHz, 80% amplitude modulation, +900 MHz keyed carrier
• Fast Transient Burst (IEC1000-4-4)	• 2 kV, 5 kHz
• Surge Immunity (IEC1000-4-5)	• 2 kV common mode, 1 kV differential mode
• Conducted Immunity (IEC1000-4-6)	• 10V, 0.15 to 80 MHz ¹

1. Conducted Immunity frequency range may be 150 kHz to 30 MHz if the Radiated Immunity frequency range is 30 MHz to 1000 MHz.

Output Specifications

Specification	1769-OB16
Voltage Category	24V dc
Operating Voltage Range	20.4V dc to 26.4V dc (source ¹)
Number of Outputs	16
Bus Current Draw (max.)	200 mA at 5V dc (1.0W)
Heat Dissipation	2.11 Total Watts (<i>The Watts per point, plus the minimum Watts, with all points energized.</i>)
Signal Delay (max.) – resistive load	turn-on = 0.1 ms turn-off = 1.0 ms
Off-State Leakage (max.) ²	1.0 mA at 26.4V dc
On-State Current (min.)	1.0 mA
On-State Voltage Drop (max.)	1.0V dc
Continuous Current Per Point (max.) <i>See the derating graphs on page 13.</i>	0.5A at 60°C (140°F) 1.0A at 30°C (86°F)
Continuous Current Per Module (max.) <i>See the derating graphs on page 13.</i>	4.0A at 60°C (140°F) 8.0A at 30°C (86°F)
Surge Current (max.) ³	2.0A (Repeatability is once every 2 seconds for a duration of 10 msec.)
Power Supply Distance Rating	8 (The module may not be more than 8 modules away from the power supply.)
Isolated Groups	Group 1: outputs 0 to 15
Output Group to Backplane Isolation	Verified by one of the following dielectric tests: 1200V ac for 1 sec. or 1697V dc for 1 sec. 75V dc working voltage (IEC Class 2 reinforced insulation)
Vendor I.D. Code	1
Product Type Code	7
Product Code	71

- Sourcing Output** - Source describes the current flow between the I/O module and the field device. Sourcing output circuits supply (source) current to sinking field devices. Field devices connected to the negative side (DC Common) of the field power supply are sinking field devices. Field devices connected to the positive side (+V) of the field supply are sourcing field devices. *Europe:* DC sinking input and sourcing output module circuits are the commonly used options.
- Typical Loading Resistor** - To limit the effects of leakage current through solid state outputs, a loading resistor can be connected in parallel with your load. Use a 5.6K ohm, ½ watt resistor for transistor outputs, 24V dc operation.
- Recommended Surge Suppression** - Use a 1N4004 diode reverse-wired across the load for transistor outputs switching 24V dc inductive loads. For additional details, refer to Industrial Automation Wiring and Grounding Guidelines, Allen-Bradley publication 1770-4.1.

Temperature Derating

The area within the curve represents the safe operating range for the module under various conditions of user supplied voltages and ambient temperatures.

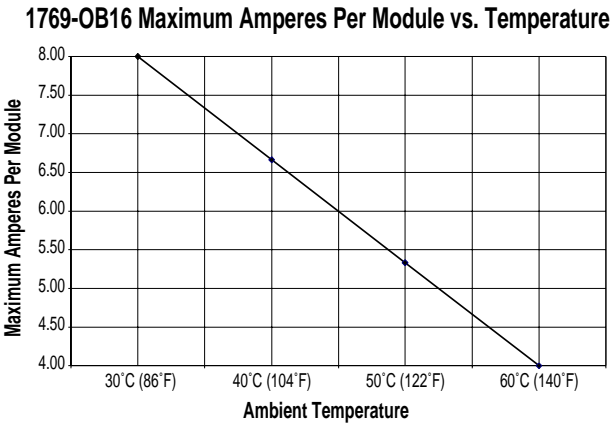
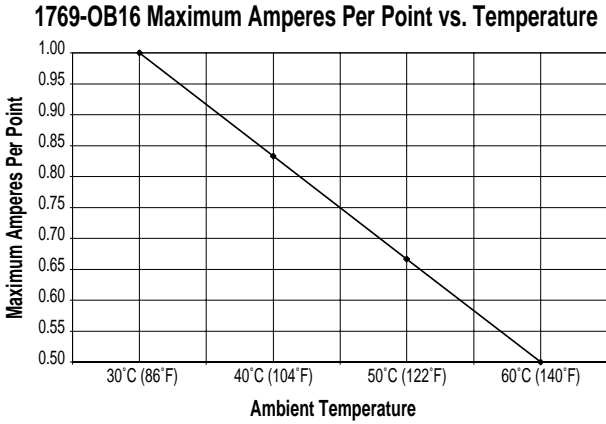

Transistor Output Transient Pulses

The maximum duration of the transient pulse occurs when minimum load is connected to the output. However, for most applications, the energy of the transient pulse is not sufficient to energize the load.



ATTENTION: A transient pulse occurs in transistor outputs when the external DC supply voltage is applied to the output common terminals (e.g. via the master control relay). The sudden application of voltage creates this transient pulse. This condition is inherent in transistor outputs and is common to solid state devices. A transient pulse can occur regardless of the controller having power or not. Refer to your controller's user manual to reduce inadvertent operation.

The graph below illustrates that the duration of the transient is proportional to the load current. Therefore, as the on-state load current increases, the transient pulse decreases. Power-up transients do not exceed the time duration shown below, for the amount of loading indicated, at 60°C (140°F).

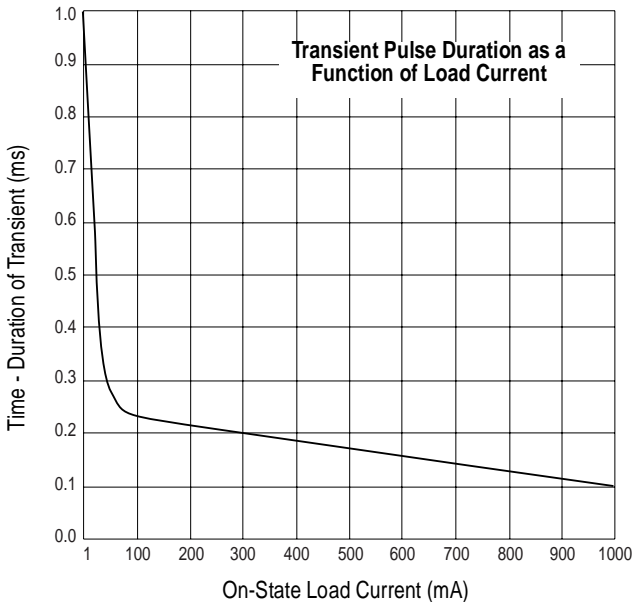

Hazardous Location Considerations

This equipment is suitable for use in Class I, Division 2, Groups A, B, C, D or non-hazardous locations only. The following ATTENTION statement applies to use in hazardous locations.



ATTENTION: EXPLOSION HAZARD

- Substitution of components may impair suitability for Class I, Division 2.
 - Do not replace components or disconnect equipment unless power has been switched off.
 - Do not connect or disconnect components unless power has been switched off.
 - This product must be installed in an enclosure.
-

Environnements dangereux

Cet équipement est conçu pour être utilisé dans des environnements de Classe 1, Division 2, Groupes A, B, C, D ou non dangereux. La mise en garde suivante s'applique à une utilisation dans des environnements dangereux.



ATTENTION: DANGER D'EXPLOSION

- La substitution de composants peut rendre cet équipement impropre à une utilisation en environnement de Classe 1, Division 2.
 - Ne pas remplacer de composants ou déconnecter l'équipement sans s'être assuré que l'alimentation est coupée.
 - Ne pas connecter ou déconnecter des composants sans s'être assuré que l'alimentation est coupée.
 - Ce produit doit être installé dans une armoire.
-

For More Information

For	Refer to this Document	Pub. No.
A more detailed description of how to install and use your Compact I/O with MicroLogix 1500 programmable controller.	<i>MicroLogix 1500 Programmable Controllers User Manual</i>	1764-6.1
More information on proper wiring and grounding techniques.	<i>Industrial Automation Wiring and Grounding Guidelines</i>	1770-4.1